

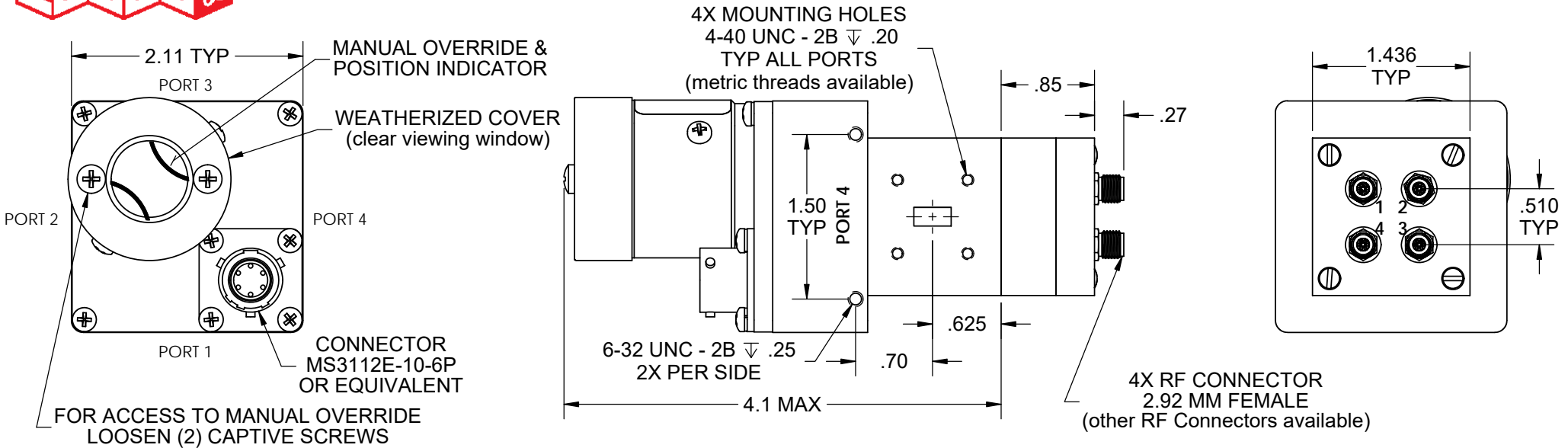

# Waveguide Switch - MW Series - WR34/2.92 MM DUAL

REV. A



(See Model # Chart to select options)

ELECTRICAL CIRCUIT OPTIONS
NO INDICATORS
1 SET INDICATORS
2 SETS INDICATORS
3 SETS INDICATORS
4 SETS INDICATORS
INHIBIT CIRCUITS

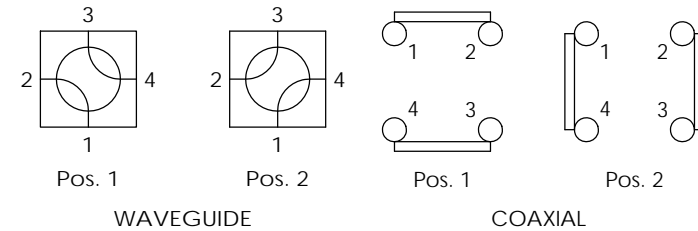

	Wave Guide		Coaxial			
Frequency: (GHz)	22.0 to 33.0	DC to 6	6 to 12	12 to 18	18 to 26.5	26.5 to 40
VSWR: (Max.)	1.10:1	1.3:1	1.4:1	1.5:1	1.7:1	2.0:1
Insertion Loss: (Max.)	0.15 dB	0.2 dB	0.4 dB	0.5 dB	0.7 dB	0.9 dB
Isolation: (Min.)	60 dB	70 dB	60 dB	60 dB	55 dB	50 dB

Flange:	See Flange Table
Voltage:	See Voltage Table
Switching Time	80 mS Max.
Material:	Aluminum (RF Assy)
Finish:	Iridite per MIL-DTL-5541 Paint Dull Black Enamel
Pressure:	30 PSIG (RF Head Only)
Drive:	Patented Logus I Motor

DRIVE OPTIONS
LATCHING
PULSE LATCHING
FAILSAFE
TTL

VOLTAGE OPTIONS
12 VDC
15 VDC
24 VDC
28 VDC
48 VDC
115 VAC

FLANGE OPTIONS
UG COVER
UG GROOVE
UG CHOKE

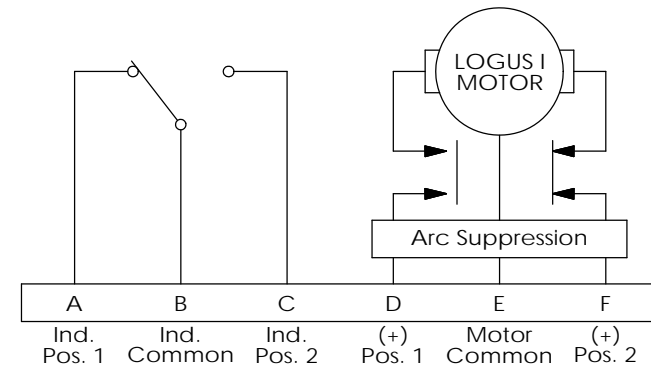

LATCHING, SHOWN IN POSITION 1

(See Schematic page for optional Electrical Circuits)

Temp:	Operating: -40 °C to +85 °C Non-Operating: -55 °C to +100 °C
Humidity:	0 to 100%, Fully Weatherized

RoHS Available